

# Jurnal-3.pdf

*by*

---

**Submission date:** 26-Sep-2023 03:30PM (UTC+0700)

**Submission ID:** 2177344006

**File name:** Jurnal-3.pdf (2.27M)

**Word count:** 4990

**Character count:** 23027



## FATIGUE ANALYSIS OF CATENARY MOORING SYSTEM DUE TO HARSH ENVIRONMENT IN FOLLOWING SEAS

Fuad Mahfud Assidiq<sup>1</sup>, Daeng Paroka<sup>1</sup>, Muhammad Zubair Muis Alie<sup>1</sup>, Syerly Klara<sup>2</sup>

<sup>1</sup>*Ocean Engineering, Hasanuddin University*

<sup>2</sup>*Marine Engineering, Hasanuddin University*

[fuadassidiq9@gmail.com](mailto:fuadassidiq9@gmail.com)

### ABSTRACT

In the operation, Floating Production Unit (FPU) will get dynamic loads on the structure periodically such as the mooring line responses. The aim of the present study to discuss fatigue life on catenary mooring system refers to the comparison of using or without using the Single Line Freestanding Riser (SLFR), the operational design and installation conditions at FPU Gendalo-Gehem and located in the Makassar Strait using the six-strand wire rope with 0,115 meters outer diameter and 1.200 meters length will be fatigue life analysed. The FPU motion observation shows the highest Response Amplitude Operator (RAO) surge, sway, heave, roll, pitch, and yaw motion due to harsh environments are 0,615 m/m,  $1,01 \times 10^{-6}$  m/m, 1,048 m/m,  $1,14 \times 10^{-5}$  0/m, 2,23 0/m, and  $9,08 \times 10^{-8}$  0/m. It means that the amplitude response will always be smaller than the wave amplitude coming up. Taking into RAO motion calculation, the fatigue life on catenary mooring systems for following seas are 445 years in mooring line 1 and mooring line 8 with using SLFR while without using SLFR for 5.461 years in mooring line 1. The structure is still in safe condition because of the design safety factor about 300 years.

**Keywords:** Catenary, Fatigue Life, Following Seas, FPU, SLFR

### ABSTRAK

Dalam tahap operasinya, *Floating Production Unit* (FPU) akan menerima beban dinamis secara periodik seperti pada *mooring line*. Tujuan dari penelitian ini untuk membahas umur kelelahan pada sistem *catenary mooring system* mengacu pada perbandingan menggunakan atau tanpa *Single Line Freestanding Riser* (SLFR), dimana desain kondisi operasional dan instalasi FPU Gendalo-Gehem di Selat Makassar dengan menggunakan *six-strand wire rope* berdiameter luar 0,115 meter dan sepanjang 1.200 meter akan dianalisis *fatigue life* nya. Meninjau gerak FPU menunjukkan bahwa maksimum nilai *Response Amplitude Operator* (RAO) pada gerak *surge, sway, heave, roll, pitch, and yaw* saat kondisi *harsh environment* adalah 0,615 m/m,  $1,01 \times 10^{-6}$  m/m, 1,048 m/m,  $1,14 \times 10^{-5}$  0/m, 2,23 0/m, and  $9,08 \times 10^{-8}$  0/m. Hal ini berarti bahwa amplitudo respon akan selalu lebih kecil dibanding amplitudo gelombang datang. Dengan menghitung gerakan RAO terjadi, *fatigue life* pada *catenary mooring system* senilai 445 tahun pada mooring line 1 dan 8 dengan menggunakan SLFR sementara tanpa menggunakan SLFR senilai 5.461 tahun pada mooring line 1. Struktur ini masih dalam kondisi aman karena *safety factor design* sekitar 300 tahun.

**Kata kunci:** *Catenary, Fatigue Life, Following Seas, FPU, SLFR*

### INTRODUCTION

Floating Production Unit Gendalo-Gehem Chevron Indonesia Company, which Indonesian Deepwater Development (IDD) mega project is located in the Makassar Strait about 6.000 feet water depths as shown in Figure 1. The project will include two development hubs, FPU with subsea drilling center, and condensate pipelines and onshore facilities. The natural gas will be used both domestically and also converted to LNG in Bontang, East Kalimantan to be exported. The maximum daily production is expected to 1,1 billion cubic feet of natural gas and 31.000 barrels of condensate.



The direction affected the wave heading angle ( $\mu$ ), which is the angle between the direction of wave propagation and the ship direction rate. The angle setting of load heading can be seen in the illustration Figure 3., and Table 1. (Sun & Wang, 2010).

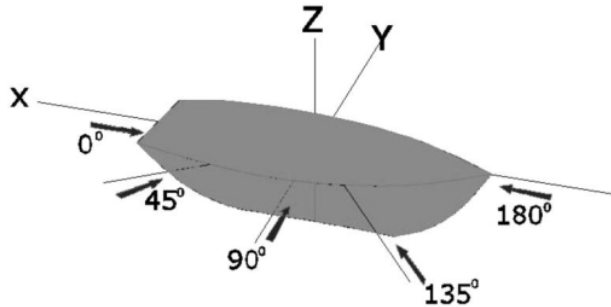

Figure 3. Heading direction in Ansys software

Table 1. Main Heading

No	Heading	Description
1	0°	Following Seas
2	45°	Stern Quartering Seas
3	90°	Beam Seas
4	135°	Bow Quartering Seas
5	180°	Head Seas

Response Amplitude Operator (RAO) is a tool to the wave forces transfer into the dynamic response of structures. RAO equation can be searched by the formula below (Chakrabarti, 1987):

$$RAO(\omega) = \frac{X_p(\omega)}{\eta(\omega)} \dots\dots\dots(2)$$

Where:

- $X_p(\omega)$  = Structure amplitude (meters)
- $\eta(\omega)$  = Wave amplitude (meters)

Mooring systems typically have 8 to 16 mooring lines consist of the heavy chain, steel wire rope and polymer materials that connected anchor toward the seabed. The catenary system paths to arrive at the seabed horizontally, while taut mooring tethered to an angle formed (Vryh Anchors BV, 2010). Another important difference is that the strength the recovery on the catenary mooring generated by the weight of the components while the taut mooring strength comes from the elasticity of the mooring lines. In Figure 4., are shown in the mooring system configurations (Larsen, 2014).

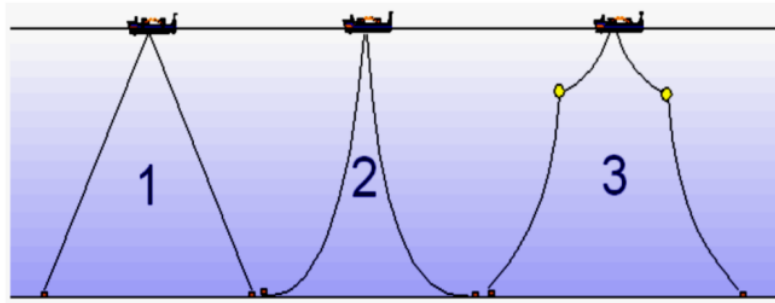

Figure 4. Mooring System Configurations; (1) taut Mooring, (2) catenary Mooring, and (3) catenary mooring with buoyancy

Tension happens to the mooring line can be divided into two: the mean tension and maximum tension. Mean tension is tension on the mooring line relating to the mean offset of the vessel. While the tension is the mean maximum tension under the effect combination of wave frequency and low-frequency tension (Chrolenko, 2013).

Limitation of tension on the mooring line and safety factor recommended by American Petroleum Institute are as follows (API RP 2SK, 2005):

Table 2. Criteria and Limit Tension Safety Factor Mooring

Case	Analysis Method	Tension Limit (Percent of MBS)	Equivalent Factor of Safety
Intact (ULS)	Dynamic	60	1,67

The fatigue analysis is defined as research that includes global dynamic motion and local stress of catenary mooring tension. The existing methodology did not have the consistency and transparency level necessary to independently demonstrate the safety level and conservatism in the design of the catenary (Nugteren, 2015).

The basis of the S-N curve about the plot of stress (S) versus the number of cycles (N). This curve is used to express the characteristics of fatigue in materials that due to cycle loads at a constant magnitude (Bannantine et al., 1990). The accuracy level is affected by the determination of S-N curve slope parameter and interception, the analytical expression of the S-N curve is (DNV OS E301, 2004):

$$N_i(s) = aD \cdot s^{-m} \dots\dots\dots(4)$$

Where:

- N<sub>i</sub>(s) = Cycle of failure
- s = Stress range (N/mm<sup>2</sup>)
- aD = Intercept parameter in S-N curve
- m = S-N curve slope

Meanwhile, aD and m parameter explanation are given in Table 3. and S-N curve is shown in Figure 5.

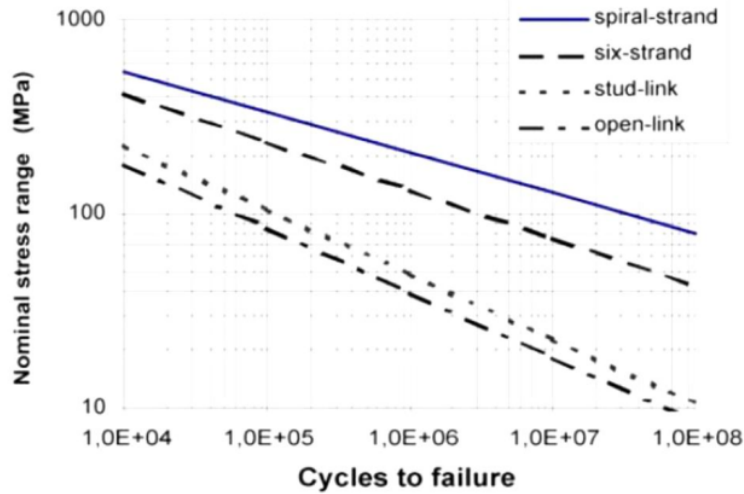

Figure 5. S-N Curve

Table 3. S-N curve parameter

Mooring Types	aD	m
Stud Chain	1,2 x 10 <sup>11</sup>	3,0
Studless Chain (Open Link)	6,0 x 10 <sup>10</sup>	3,0
Six-Strand Wire Rope	3,4 x 10 <sup>14</sup>	4,0
Spiral Strand Wire Rope	1,7 x 10 <sup>17</sup>	4,8

To obtain the fatigue life on each mooring lines takes into the further process between the number of cycles-stress range and mooring line characteristics (Nallayarasu, 2015). This fatigue life review when the condition of the surge, sway, heave, roll, pitch and yaw motion by heading 0° (following seas) were calculated as follows (Nugteren, 2015):

$$n = \frac{T}{T_a} \dots\dots\dots(5)$$

$$D = \sum_{i=1}^n \frac{n}{N_i} \dots\dots\dots(6)$$

Where:

- n = Number of cycle
- D = Fatigue damage ratio
- T = Design life period (sec)
- T<sub>a</sub> = Stress range period (sec)
- N<sub>i</sub> = Cycles of failure

While the fatigue life calculations (in years) are from the total fatigue damage, and the safety factor at least about 10 (API RP 2RD, 1998), and additional safety between 0 and 1.

$$\text{Fatigue Life} = \frac{1}{N_i \times (10 + \text{additional safety})} \dots\dots\dots(7)$$



As well as the fatigue life in safety design criteria for mooring lines as follows (Larsen et al., 2014):

Fatigue Life > Design Life .....(8)

RESEARCH METHODS

The research was conducted by literature review and FPU supporting data as in Table 4., Table 5., and Table 6., then do the FPU modeling using SLFR and without using SLFR simulation in following seas to find fatigue life on catenary mooring system when using or without using SLFR effectively. The review with using or without using SLFR FPU and its load heading direction indicated in Figure 6., and Figure 7.

Analyzing motion response FPU using Ansys AQWA to get stress range each mooring lines. Stress range of each mooring lines obtained from the time domain analysis to the catenary mooring system based FPU motion responses in the heading direction 0° so that resulting from the tensions due to each mooring lines affected when using SLFR and without using SLFR. To obtain the fatigue life of each mooring lines takes the process further between the stress range-failure and characteristics of the mooring line used against loading period following the DNV (Det Norske Veritas) and the API (American Petroleum Institute) criteria and then get the conclusion.

Table 4. FPU Main Dimention

Table with 2 columns: Dimension, Value. Rows: LOA (160,5 m), B (50,0 m), H (17,0 m), T (8,40 m), Cb (0,98)

Table 5. FPU Mooring Data

Table with 2 columns: Property, Value. Rows: Mass / Unit Length (140 kg/m), Outer Diameter (0,115 m), Section Length (1.200 m), Stiffness, EA (1 x 10^9 N), Maximum Tension (8 x 10^6 N)

Table 6. Makassar Strait Wave Scatter Data

Table with 8 columns: Hs/Tp, 02-Mar, 03-Apr, 04-Mei, 05-Jun, 06-Jul, 07-Agt, Total. Rows: 0,00-0,25, 0,25-0,50, 0,50-0,75, 0,75-1,00, 1,00-1,25, 1,25-1,50

1,50-1,75	0,00	0,17	0,46	0,29	0,29	0,02	1,23
1,75-2,00	0,00	0,00	0,17	0,19	0,07	0,00	0,43
2,00-2,25	0,00	0,00	0,02	0,02	0,00	0,00	0,04
Total	11,80	31,86	22,83	16,31	13,98	3,22	100

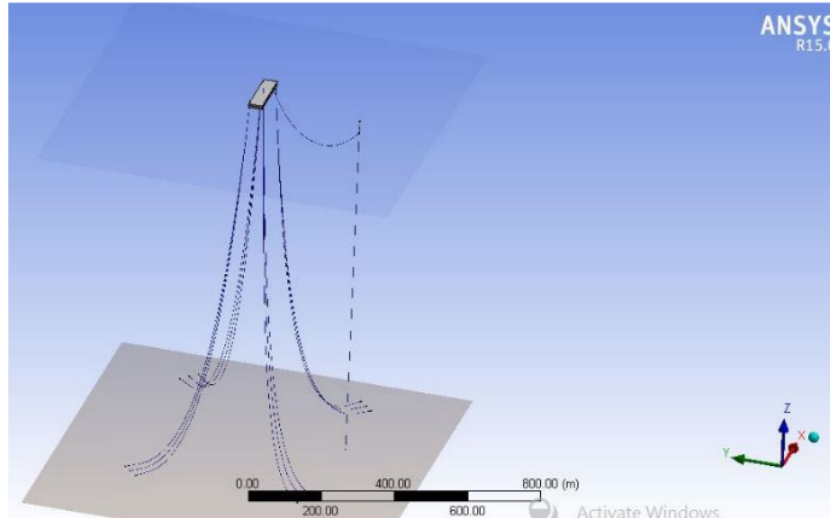

Figure 6. FPU and SLFR

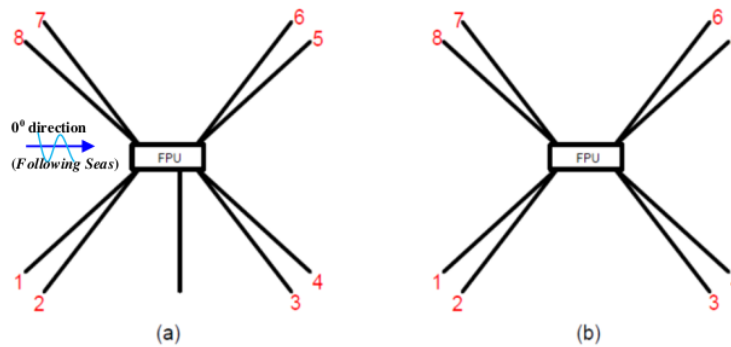

Figure 7. Mooring line numbering;  
(a) using SLFR and (b) without using SLFR

**FINDINGS AND DISCUSSION**

The Hydrostatics FPU Gendalo-Gehem analysis results obtained from the running hydrodynamic diffraction which considered heave, roll, and pitch motion. The hydrostatics results as the function of the FPU geometrical characteristics.

Table 7 and Table 8 seen that using SLFR and without using SLFR on FPU in Ansys Aqwa are very influential in the vertical mode like heave motion at the RX and RY-axis, roll motion at the RY-axis, pitch motion at the Z and RX-axis, volumetric displacement, center of buoyancy position, distance COG to COB and metacentric height due to the the vertical motion modes



(heave, roll and pitch motion) have stiffness factor that may affect the damping factor becomes be smaller so it will produce the highest characteristics result when its resonance happened.

When FPU in horizontal motion mode (surge, sway, yaw motion) have more important influential because it will affect the stiffness of damping factor becomes larger so that no change in the characteristics rise up significantly.

Table 7. FPU hydrostatic result using SLFR in Ansys Aqwa

<b>Hydrostatic Stiffness</b>			
Centre of Gravity Position:	<b>X:</b> 80,25 m	<b>Y:</b> 25,00 m	<b>Z:</b> 0,00 m
	<b>Z</b>	<b>RX</b>	<b>RY</b>
Heave(Z):	80.665.544 N/m	8,448 N/°	4,176 N/°
Roll(RX):	484,063 N.m/m	1,940E+08 N.m/°	3,427 N.m/°
Pitch(RY):	239,271 N.m/m	3,427 N.m/°	2,923E+09 N.m/°
<b>Hydrostatic Displacement Properties</b>			
Actual Volumetric Displacement:	134.819,970 m <sup>3</sup>		
Equivalent Volumetric Displacement:	134.819,520 m <sup>3</sup>		
Centre of Buoyancy Position:	<b>X:</b> 80,25 m	<b>Y:</b> 25,000002 m	<b>Z:</b> -4,1999927 m
Out of Balance Forces/Weight:	<b>FX:</b> 9,22E-07	<b>FY:</b> 1,56E-04	<b>FZ:</b> 2,93E-03
Out of Balance Moments/Weight:	<b>MX:</b> 1,58E-07 m	<b>MY:</b> -7,82E-08 m	<b>MZ:</b> 1,0036E-07 m
<b>Cut Water Plane Properties</b>			
Cut Water Plane Area:	8.024,972 m <sup>2</sup>		
Centre of Floatation:	<b>X:</b> 80,25 m	<b>Y:</b> 25,000006 m	
Principal 2nd Moment of Area:	<b>X:</b> 1.671.873 m <sup>4</sup>	<b>Y:</b> 17.227.168 m <sup>4</sup>	
Angle Principal Axis makes with X (FRA):	4,122E-06 °		
<b>Small Angle Stability Parameters</b>			
C.O.G. to C.O.B.(BG):	4,1999927 m		
Metacentric Heights (GMX/GMY):	8,2007885 m	123,57906 m	
COB to Metacentre (BMX/BMY):	12,400781 m	127,77905 m	
Restoring Moments/Degree Rotations (MX/MY):	3,385.393 N.m/°	51.015.060 N.m/°	

Table 8. FPU hydrostatic result without using SLFR in Ansys Aqwa

<b>Hydrostatic Stiffness</b>			
Centre of Gravity Position:	<b>X:</b> 80,25 m	<b>Y:</b> 25,00 m	<b>Z:</b> 0,00 m
	<b>Z</b>	<b>RX</b>	<b>RY</b>
Heave(Z):	80.666.000 N/m	4,090 N/°	3,041 N/°
Roll(RX):	234,362 N.m/m	1,940E+08 N.m/°	13,706 N.m/°
Pitch(RY):	174,238 N.m/m	13,706 N.m/°	2,923E+09 N.m/°
<b>Hydrostatic Displacement Properties</b>			
Actual Volumetric Displacement:	134.819,91 m <sup>3</sup>		



<b>1</b>	Equivalent Volumetric Displacement:			134.819,52 m <sup>3</sup>	
	Centre of Buoyancy Position:	<b>X:</b>	80,25 m	<b>Y:</b>	25,00 m
		<b>Z:</b>	-4,2000031 m		
	Out of Balance Forces/Weight:	<b>FX:</b>	7,38E-07	<b>FY:</b>	1,20E-05
		<b>FZ:</b>	4,63E-02		<b>3</b>
	Out of Balance Moments/Weight:	<b>MX:</b>	3,690E-08 m	<b>MY:</b>	-6,132E-07 m
		<b>MZ:</b>	-2,952E-08 m		<b>3</b>
<b>Cut Water Plane Properties</b>					
	Cut Water Plane Area:			8.025,018 m <sup>2</sup>	
	Centre of Floatation:	<b>X:</b>	80,25 m	<b>Y:</b>	25.000004 m
	Principal 2nd Moment of Area:	<b>X:</b>	1.671.876 m <sup>4</sup>	<b>Y:</b>	17.227.170 m <sup>4</sup>
	Angle Principal Axis makes with X (FRA):			1,649E-05 °	<b>3</b>
<b>Small Angle Stability Parameters</b>					
	C.O.G. to C.O.B.(BG):			4,2000031 m	
	Metacentric Heights (GMX/GMY):		8,2008057 m		123,57912 m
	COB to Metacentre (BMX/BMY):		12,400809 m		127,77913 m
	Restoring Moments/Degree Rotations (MX/MY):		3.385.399 N.m/°		51.015.060 N.m/°

The results about RAO analysis using SLFR and without SLFR by heading 0° (following seas). RAO can be seen in Figure 8., show that amplitude responses change over while using SLFR and without SLFR condition. It proves that the mooring lines can reduce the FPU motion in harsh environment with  $H_s = 4,0$  meters and  $T = 7,7$  sec.

When using SLFR, FPU motion characteristics don't exceed the maximum high waves well. It means that the RAO's amplitude responses are always smaller than the amplitude coming up. In the surge and heave motion as shown in Figure 8. (a) and Figure 8. (c) show that while using SLFR and without using SLFR by heading 0° (following seas) get the same RAO. The maximum surge motion occur when without using SLFR in 0.615 m/m and the maximum heave motion occur during using SLFR in 1,048 m/m.

The maximum roll and pitch motion occurs when without using SLFR are  $1,14 \times 10^{-5}$  /m and  $2,230$  °/m. In Figure 8. (d) and Figure 8. (e) shows that both are almost same RAO, only the amplitude responses without SLFR are greater than using SLFR. It occurs while using SLFR has 0,207 rad/sec longer frequency duration than without using SLFR.

Meanwhile, sway, and yaw motion shows that both are the different trend as shown in Figure 8. (b) and Figure 8. (f). The maximum sway motion occur when using SLFR is  $1,01 \times 10^{-6}$  m/m and from 0,1 to 0,57 rad/sec is RAO significant difference occurs. The maximum yaw motion occurs when without using SLFR is  $9,08 \times 10^{-8}$  /m and on the early frequency, 0,12 rad/sec occur the significant difference response because SLFR position are not centering of the midship so RAO when using SLFR duration occurs sooner.

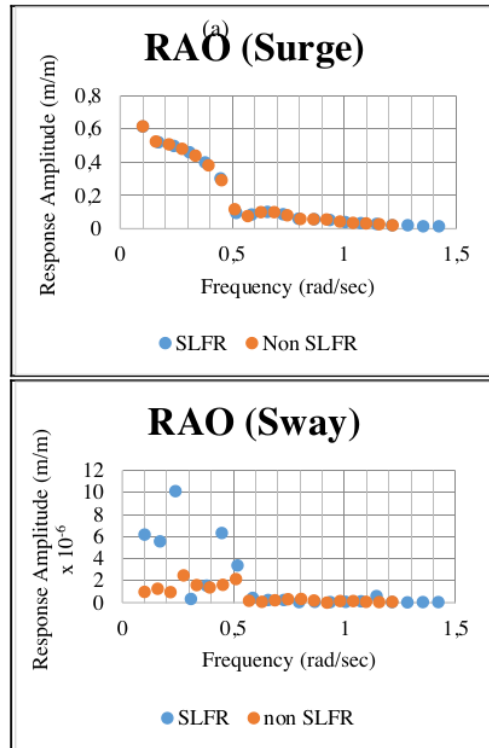

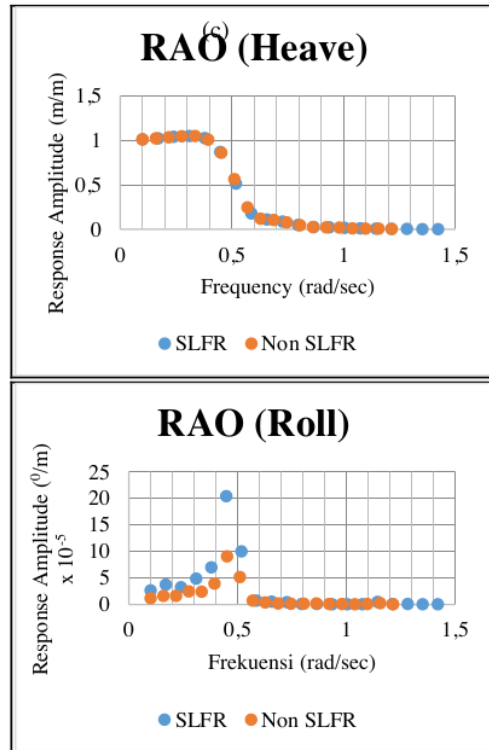

(d)

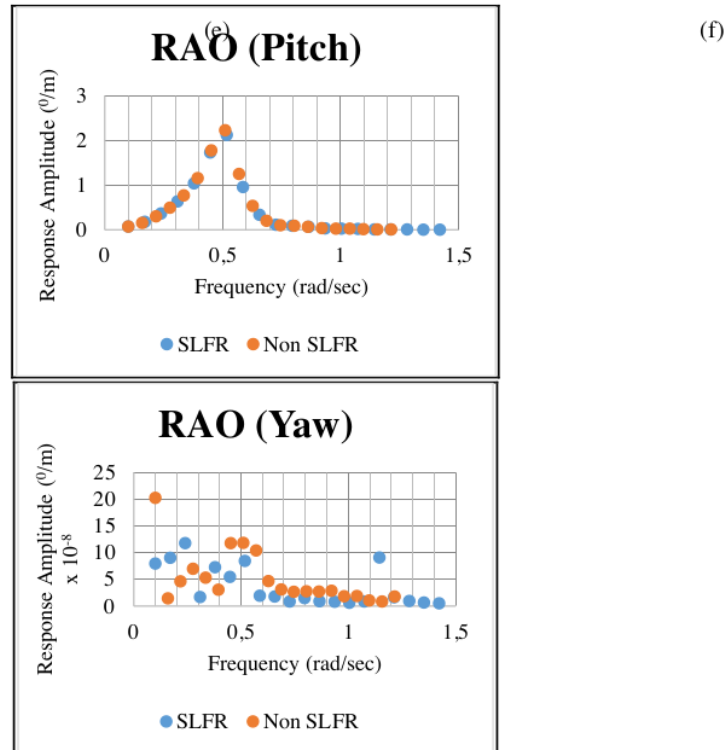

9 Figure 8. Comparison of RAO using SLFR and without SLFR; (a) surge motion, (b) sway motion, (c) heave motion, (d) roll motion, (e) pitch motion and (f) yaw motion

After getting the RAO, then stress range can be determined by the maximum and minimum mooring lines tension within difference wave periods. In Figure 9., the FPU's mooring line tension occurs when using SLFR in following seas. Form all mooring line tensions, tension trend generated are almost the same response. The maximum tension occurs in mooring line 1 worth 231.422,141 kN in 11,15 sec, and the minimum tension occurs in mooring line 5 worth 43.789,320 kN in 6,68 sec. See more in Table 9.

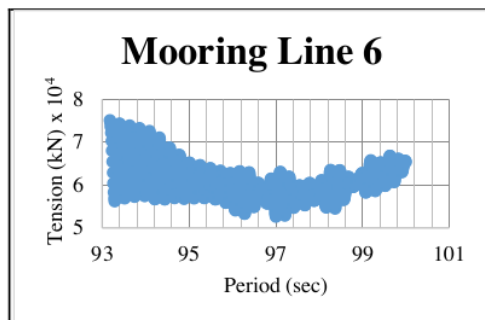
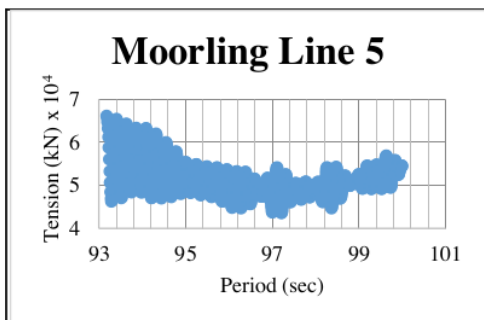
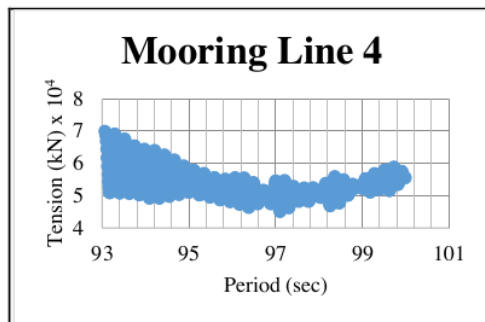
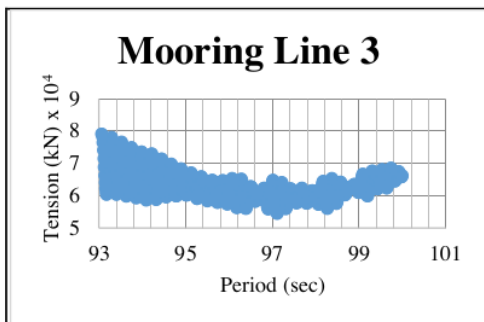
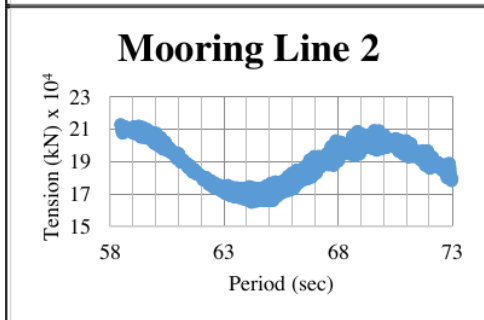
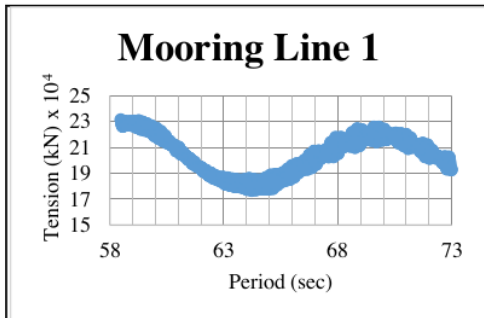

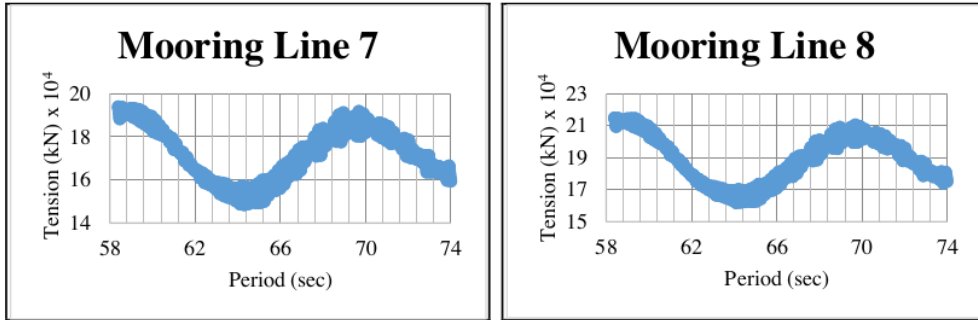
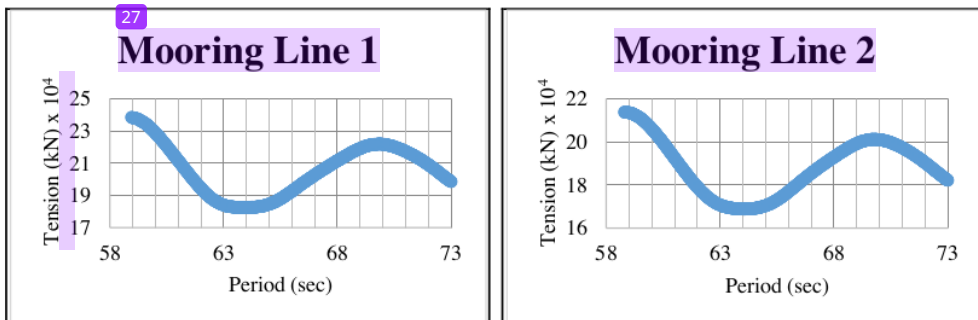

Figure 9. Tension of mooring line using SLFR

Table 9. Summary of mooring line tension using SLFR

Mooring Line	Tension [kN]			Period [Sec]
	Maximum	Minimum	Range	
1	231.422,141	177.389,530	54.032,611	11,15
2	213.093,922	165.476,583	47.617,342	11,13
3	79.051,102	54.337,336	24.713,766	6,94
4	69.953,258	45.007,715	24.945,543	6,94
5	66.114,734	43.789,320	22.325,414	6,82
6	75.048,055	52.605,527	22.442,528	6,82
7	194.010,734	149.660,95	44.349,784	11,25
8	214.919,922	162.831,66	52.088,262	11,32

In Figure 10., the FPU's mooring line tension occurs when without using SLFR in following seas. Form all mooring line tension, tension trend generated that are very similar responses because no SLFR load affects. The maximum tension occurs in mooring line 1 worth 238.392,156 kN in 11,11 sec, and the minimum tension occurs in mooring line 4 worth 46.941,477 kN in 12,11 sec. For more information about summary mooring line tension when without using SLFR see Table 10.



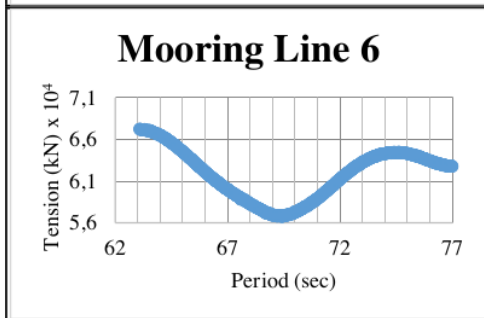
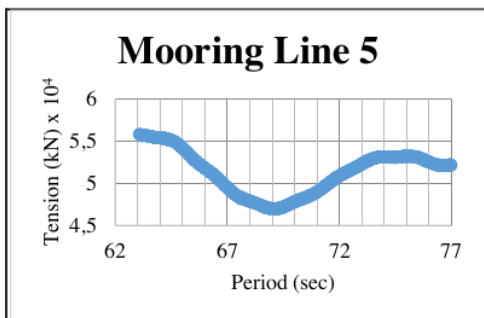
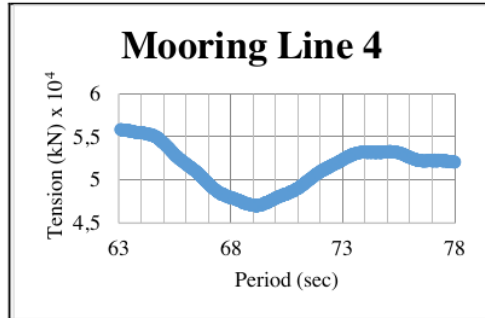
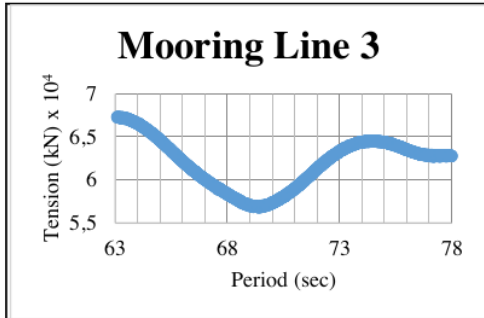

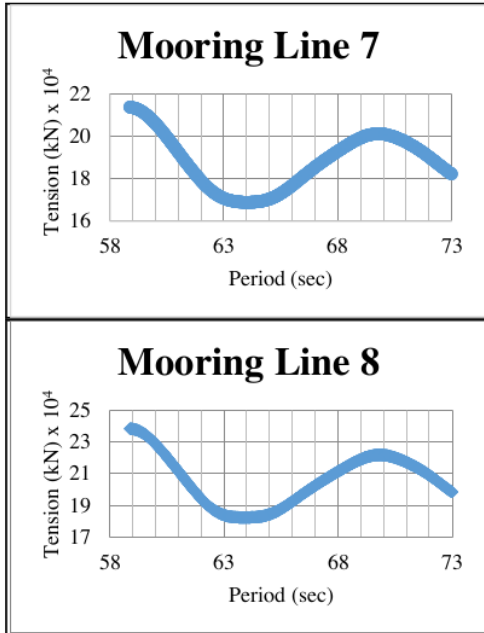

Figure 10. Tension of mooring line without using SLFR

Table 10. Summary of mooring line tension without using SLFR

Mooring Line	Tension [kN]			Period [Sec]
	Maximum	Minimum	Range	
1	238.392,156	182.479,673	55.912,486	11,11
2	213.724,047	168.780,272	44.943,777	11,08
3	67.278,414	56.835,125	10.443,289	11,44
4	55.843,320	46.941,477	8.901,843	12,11
5	55.836,906	46.953,453	8.883,453	12,19
6	67.249,445	56.798,957	10.450,488	11,41
7	213.650,875	168.769,922	44.880,955	11,11
8	238.317,938	182.404,444	55.913,498	11,12

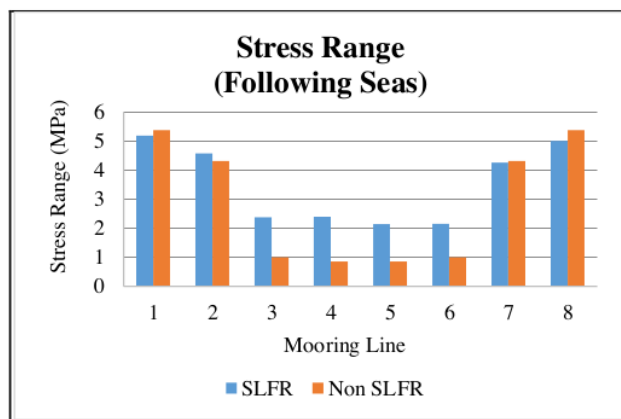

Figure 11. Comparison of stress range using SLFR and without SLFR

After getting the tension range by Table 9., and Table 10., Stress range of each mooring lines can be determined by calculating mooring line cross-sectional area were using six-strand wire rope (DNV OS E304, 2015) with the cross-sectional area  $10,382 \times 10^{-6} \text{ m}^2$ .

The stress range of mooring lines using SLFR is differently received by each mooring lines as in Figure 11. The maximum and minimum stress range of mooring line using SLFR are 5,205 MPa with 11,15 sec and 2,150 MPa with 6,82 sec. While the stress range of mooring lines without using SLFR get the similar trend for each mooring line with the maximum and minimum stress range are 5,386 MPa with 11,11 sec and 0,856 MPa with 12,15 sec.

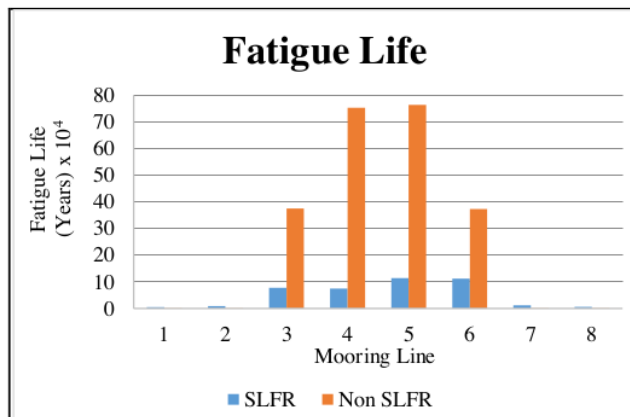

Figure 12. Comparison of fatigue life using SLFR and without SLFR

From the stress range results obtained, the fatigue life can be known. Then, we can determine the number of cycles ( $n$ ) in equation (5), fatigue damage ( $D$ ) in equation (6) and fatigue life in equation (7) where the additional safety range about 0,67 (API RP 2SK, 2005).

Based on Figure 12., comparison of fatigue life with mooring line modeling using SLFR or without SLFR take effect in the stress range and its period that get difference significantly in the mooring line 4 which it's about  $67,971 \times 10^4$  years because the SLFR located in midship area nearby the bow as in Figure 7. (a). When the heading  $0^\circ$  coming up, the mooring line 5 and mooring line 6 when using SLFR and mooring line 4 and the mooring line 5 without SLFR have major structural responses and greater tensions than other mooring lines as stress range result are greater too. The fatigue life using SLFR is smaller than without using SLFR.

At the same time, fatigue life result using SLFR is 445 years on mooring line 1 and mooring line 8 while fatigue life results without using SLFR about 5.461 years on mooring line 1.

## CONCLUSION

Form the analysis carried out can be concluded that the FPU Gendalo-Gehem motion characteristics designed by using and without using SLFR well because maximum RAO is less than the wave height. It means that the response amplitude will always be smaller than wave amplitude coming up so that the maximum RAO due to the following seas in harsh environment with  $H_s = 4,0$  meters and  $T = 7,7$  sec in the highest surge motion without using SLFR is 0,615 m/m, the highest heave motion when using SLFR is 1,048 m/m while the highest pitch motion



without using SLFR is  $2,23 \text{ }^0/\text{m}$ . Another thing happened when using SLFR has longer frequency about  $0,207 \text{ rad/sec}$  than without using SLFR

By catenary mooring system design accordingly and using SLFR calculated by following seas, the fatigue life result on catenary mooring systems in the harsh environment are 445 years by using SLFR on a mooring line 1 and mooring line 8, while 5.461 years without using SLFR on mooring line 1. So that the 30 years service life has met the API safety factor 10 so that the criteria required which are 300 years.

### ACKNOWLEDGEMENTS

The author would like to convey a great appreciation to Chevron Indonesia Company, Balikpapan, East Kalimantan, Indonesia for supporting this research data.

### REFERENCES

- API RP 2 RD, 1998. Design of Risers for Floating Production Systems (FPSs) and Tension-Leg Platforms (TLPs). USA: American Petroleum Institute.
- API RP 2 SK, 2005. Recommended Practice for Design and Analysis of Station Keeping Systems for Floating Structures. USA: American Petroleum Institute.
- Bannantine A.J., Comer J.J., Handrock L.J., 1990. Fundamental of Metal Fatigue Analysis. USA: Prentice Hall.
- Chakrabarti, S.K., 1987. Hydrodynamic of Offshore Structures. USA: Computational Mechanic Publication Southampton.
- Chrolenko, M. O., 2013. Dynamic Analysis and Design of Mooring Lines. Norway: NTNU.
- DNV OS E301, 2004. Position Mooring. Norway: Det Norske Veritas.
- DNV OS E304, 2015. Offshore Mooring Steel Wire Ropes. Norway: Det Norske Veritas .
- Faltinsen O. M, 2005. Hydrodynamics of High-Speed Marine Vehicles. New York: Cambridge University Press.
- Larsen K, 2014. Lecture Note: Mooring and Station Keeping of Floating Structures. Norway: NTNU.
- Larsen C.M, Svein Saevik, Jacob Qvist, 2014. Handbook on Design and Operation of Flexible Pipes; B1 Design Analysis. Norway: MARINTEK / NTNU / 4Subsea.
- Nallayarasu, 2015. Offshore Structures Analysis and Design. India: Indian Institute of Technology.
- Nugteren F., 2015. Flexible Riser Fatigue Analysis: Studying Conservatism in Flexible Riser Fatigue Analysis and Development of an Engineering Model to Study Influencing Parameters of Local Wire Stress. Master of Science Thesis. Netherlands: TU Delft.
- Saidee, 2015. Fatigue Analysis and Design of Mooring Systems: Assessment and Comparison of Different Methods. Master of Science Thesis. Norway: NTNU.
- Sun, J. W., Wang, S. Q, 2010. Study on Motion Performance of Deepwater Spar Platform under Different Mooring Methods. China: Period of Ocean University of China.
- Vryh of Anchors BV, 2010. Anchor Manual: The Guide Anchoring. Netherlands: Capelle a/d Yssel.

# Jurnal-3.pdf

---

## ORIGINALITY REPORT

---

13%

SIMILARITY INDEX

11%

INTERNET SOURCES

4%

PUBLICATIONS

7%

STUDENT PAPERS

---

## PRIMARY SOURCES

---

1	<a href="https://repository.its.ac.id">repository.its.ac.id</a> Internet Source	2%
2	<a href="https://hdl.handle.net">hdl.handle.net</a> Internet Source	1%
3	Submitted to University Of Tasmania Student Paper	1%
4	<a href="https://brage.bibsys.no">brage.bibsys.no</a> Internet Source	1%
5	<a href="https://repository.tudelft.nl">repository.tudelft.nl</a> Internet Source	1%
6	<a href="https://ejournal3.undip.ac.id">ejournal3.undip.ac.id</a> Internet Source	1%
7	<a href="https://isomase.org">isomase.org</a> Internet Source	<1%
8	<a href="https://journal.unhas.ac.id">journal.unhas.ac.id</a> Internet Source	<1%
9	<a href="https://strathprints.strath.ac.uk">strathprints.strath.ac.uk</a> Internet Source	<1%

---

10	Submitted to IIT Delhi Student Paper	<1 %
11	kipdf.com Internet Source	<1 %
12	R. Stonor. "Development of an Engineers' Design Guide for Deepwater Fiber Moorings", Proceedings of Offshore Technology Conference OTC, 05/1999 Publication	<1 %
13	ntnuopen.ntnu.no Internet Source	<1 %
14	repository.unhas.ac.id Internet Source	<1 %
15	Submitted to Harper Adams University College Student Paper	<1 %
16	Hui-Min Hou, Guo-Hai Dong, Tiao-Jian Xu, Yun-Peng Zhao, Chun-Wei Bi, Fu-Kun Gui. "Fatigue reliability analysis of mooring system for fish cage", Applied Ocean Research, 2018 Publication	<1 %
17	Submitted to MLA College Student Paper	<1 %
18	Submitted to Nanyang Technological University, Singapore Student Paper	<1 %

19

Zhenju Chuang, Xin Chang, Bingjie Guo, Yu Lu. "Dynamic analysis of semi-submersible production platform under the failure of mooring lines", Engineering Failure Analysis, 2020

Publication

<1 %

20

studentsrepo.um.edu.my

Internet Source

<1 %

21

killajoules.wikidot.com

Internet Source

<1 %

22

123dok.com

Internet Source

<1 %

23

Chana Sinsabvarodom, Bernt J. Leira, Wei Chai, Arvid Næss. "Short-term extreme mooring loads prediction and fatigue damage evaluation for station-keeping trials in ice", Ocean Engineering, 2021

Publication

<1 %

24

stackoverflow.com

Internet Source

<1 %

25

Submitted to Cranfield University

Student Paper

<1 %

26

Kawai, Masamichi. "Fatigue of Composites-Life Prediction Methods", Wiley Encyclopedia of Composites, 2012.

Publication

<1 %

27

Kwansu Kim, Hyunjong Kim, Hyungyu Kim, Jaehoon Son, Jungtae Kim, Jongpo Park.  
"Resonance Avoidance Control Algorithm for Semi-Submersible Floating Offshore Wind Turbine", *Energies*, 2021

Publication

<1 %

28

Mostafa Shahrabi, Khosrow Bargi.  
"Enhancement the Fatigue Life of Floating Breakwater Mooring System Using Tuned Liquid Column Damper", *Latin American Journal of Solids and Structures*, 2019

Publication

<1 %

29

"Chapter 300143 Data Analysis", Springer Science and Business Media LLC, 2022

Publication

<1 %

Exclude quotes  On

Exclude matches  < 5 words

Exclude bibliography  On